



Treaty Series No. 98 (1991)

Amendments
to Annexes 2 and 7
of the Customs Convention on the
International Transport of Goods
under Cover of TIR Carnets
(TIR Convention)

Done at Geneva on 14 November 1975

[The Amendments entered into force on 1 August 1989]

*Presented to Parliament
by the Secretary of State for Foreign and Commonwealth Affairs
by Command of Her Majesty
December 1991*

LONDON : HMSO

£1.00 net

AMENDMENTS¹
TO ANNEXES 2 AND 7 OF THE CUSTOMS CONVENTION OF THE
INTERNATIONAL TRANSPORT OF GOODS UNDER COVER OF TIR CARNETS
(TIR CONVENTION)²

ANNEXES 2 AND 7

Annex 2, article 3, paragraph 9

Annex 7, part I, article 4, paragraph 9

Insert after the existing text, the following wording:

“ . . . In cases where the sheet has to be fixed to the frame in a system of construction which otherwise complies with the provisions of paragraph 6(a) of this article, a thong can be used as fastening (an example of such a system of construction is given in sketch No. 7 appended to this annex). The thong has to comply with the requirements stipulated in paragraph 11(c) with regard to material, dimensions and shape.”

Sketch No. 7

EXAMPLE OF SHEETS FIXED TO SPECIAL-SHAPED FRAMES

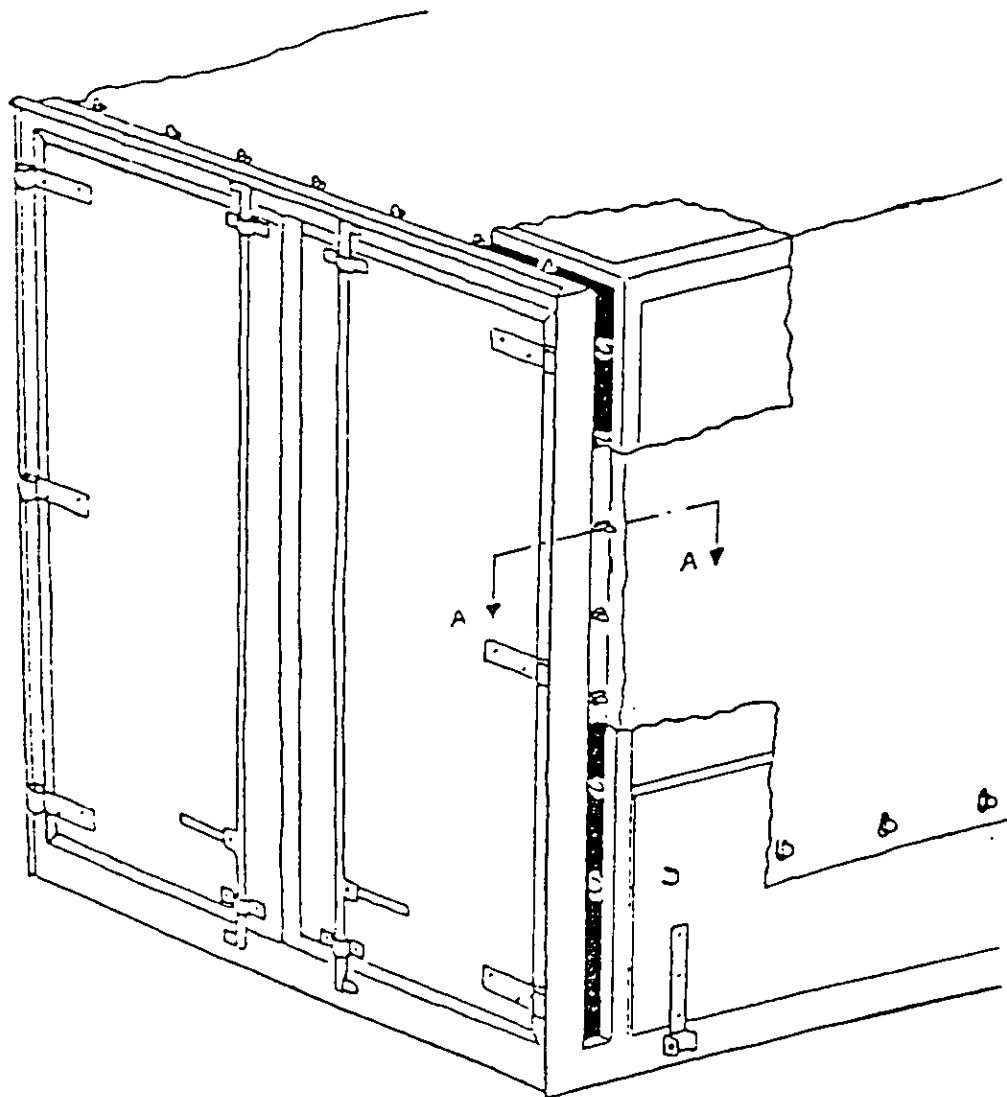

¹ Amendments were adopted by Administrative Committee at its Eleventh Session held in Geneva 24-25 November 1988 in accordance with article 59(1) and (2) of the Convention and circulated by the Secretary-General of the United Nations 30 March 1989. They entered into force for all Contracting Parties on 1 August 1989 in accordance with the provisions of Article 60 of the Convention.

² Treaty Series No. 56 (1983) Cmnd.9032.

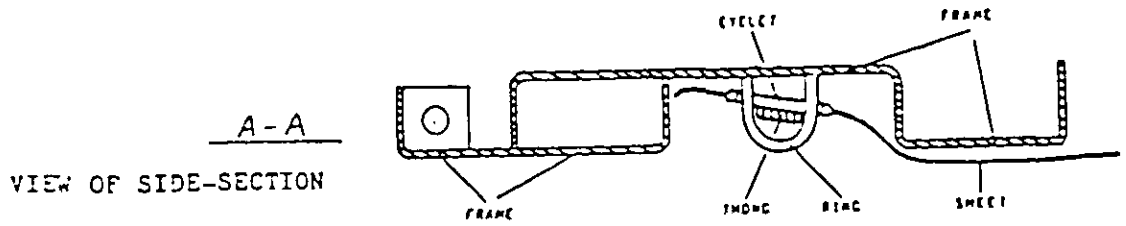

Description

This fastening of the sheet to the vehicle is acceptable provided that the rings are recessed in the profile and do not protrude more than the maximum depth of the profile. The width of the profile shall be as narrow as possible.

